



Features

Eco-Friendly Refrigerant

R290 refrigerant with a global warming potential (GWP) of 3

High-Strength, Full-Extension Drawers

Premium slide and framework construction promotes lateral stability while offering high dynamic load capacities and a stay-shut feature

Stainless Steel Exterior

Galvanized back and bottom to reduce the risk of corrosion

Long-Lasting, Removable Gaskets

Santorprene™ gaskets last four times longer than standard gaskets

Heavy-Duty Casters

Secured to a 12 gauge steel base to ensure years of worry-free operation

High-Efficiency Refrigeration System

Forced air circulation provides uniform temperature throughout the cabinet

Drawer Capacity

Each drawer includes two (2) divider bars to accommodate three (3) full-size 12"W x 20"H x 6"D hotel pans — additional adapters are available for fractional pans

Easy to Clean

Aluminum interior, coved corners, finished edges, plus full-extension and easy lift out drawers

High-Density Insulation

Foamed-in-place, CFC-free polyurethane insulation for maximum strength, rigidity, and insulation

Flat Top with Corner Brackets

Corner brackets assist in preventing movement of cooking equipment — includes top handles for mobility

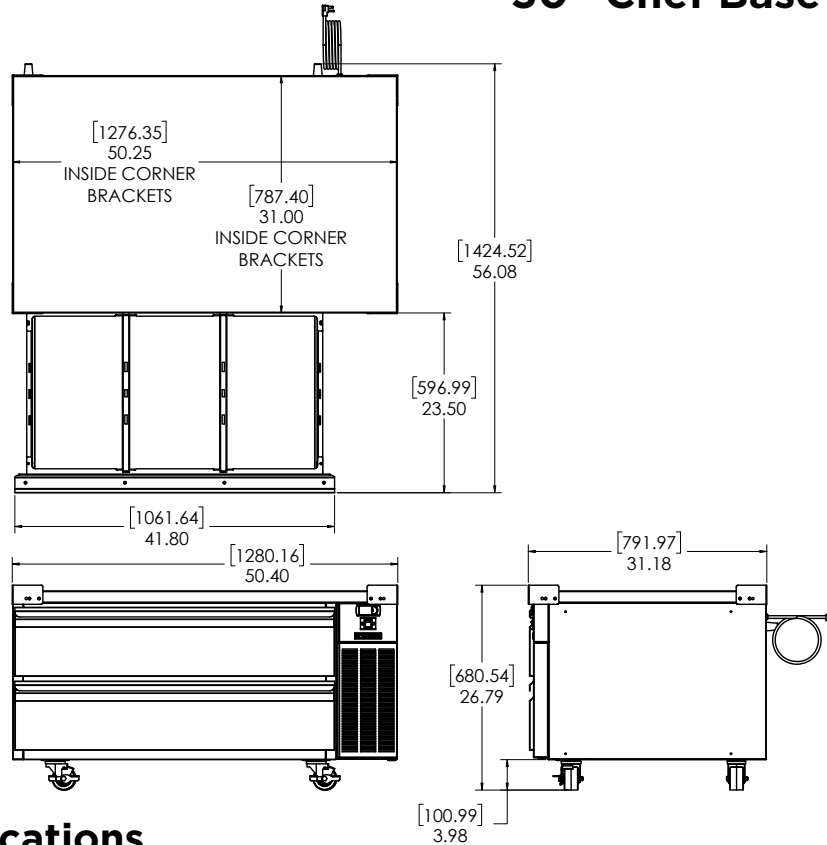

Technical Specifications

Electrical Requirements	115v/60hz/1ph/2A/NEMA 5-15P Plug
Product Dimensions	50.40"W x 26.79"H x 32.66"D (128.02cm x 68.05cm x 82.96cm)
Product Weight	315lbs (142.88kg)
Shipping Dimensions	55"W x 30"H x 36"D (139.70cm x 76.20cm x 91.44cm)
Shipping Weight	350lbs (158.76kg)
Shipping Cubic Dimensions	34.38ft ³ (0.97m ³)
Temperature Range	36 to 40°F (2.2 to 4.4°C)
Refrigerant	R290
Charge Level	4.0oz (113 grams)
Insulation	CFC-free polyurethane foam-in-place insulation

Exterior Construction	Stainless steel exterior with galvanized back and bottom
Interior Construction	Aluminum interior with coved corners and finished edges
Drawers	Two (2) high-strength, full-extension drawers with dividers
Capacity	Six (6) full-size 12"W x 20"H x 6"D hotel pans
Door/Drawer Gasket	Santoprene™ gasket
Casters	Four (4) 4" heavy-duty casters
Certifications	ETL Safety, ETL Sanitation
Warranty	1-year parts and labor, 5-year compressor (part only)

Model Number	Description
SKRCB50H-EDUS4	Chef Base Refrigerator 50", 115v/6hz/1ph/2A, flat top with corner brackets, 2 drawer, 4" heavy-duty casters, NEMA 5-15P

Accessories	Description
25567	Adapter Bars for Fractional Pans
43581	Pan 1/6 Size, 4" Deep Plastic
43643	Pan 1/6 Size, 6" Deep Plastic
27066	Pan 1/3 Size, 4" Deep Plastic
26415	Pan 1/3 Size, 6" Deep Plastic

To learn more about **Chef Base Refrigerator**, visit silverking.com